

CIVA

FAI

AEROBATICS
COMMISSION

EAAC 2019 1st - 11th Aug

Form B

Pilot ID

CIVA Advanced Unknown3

Flight #

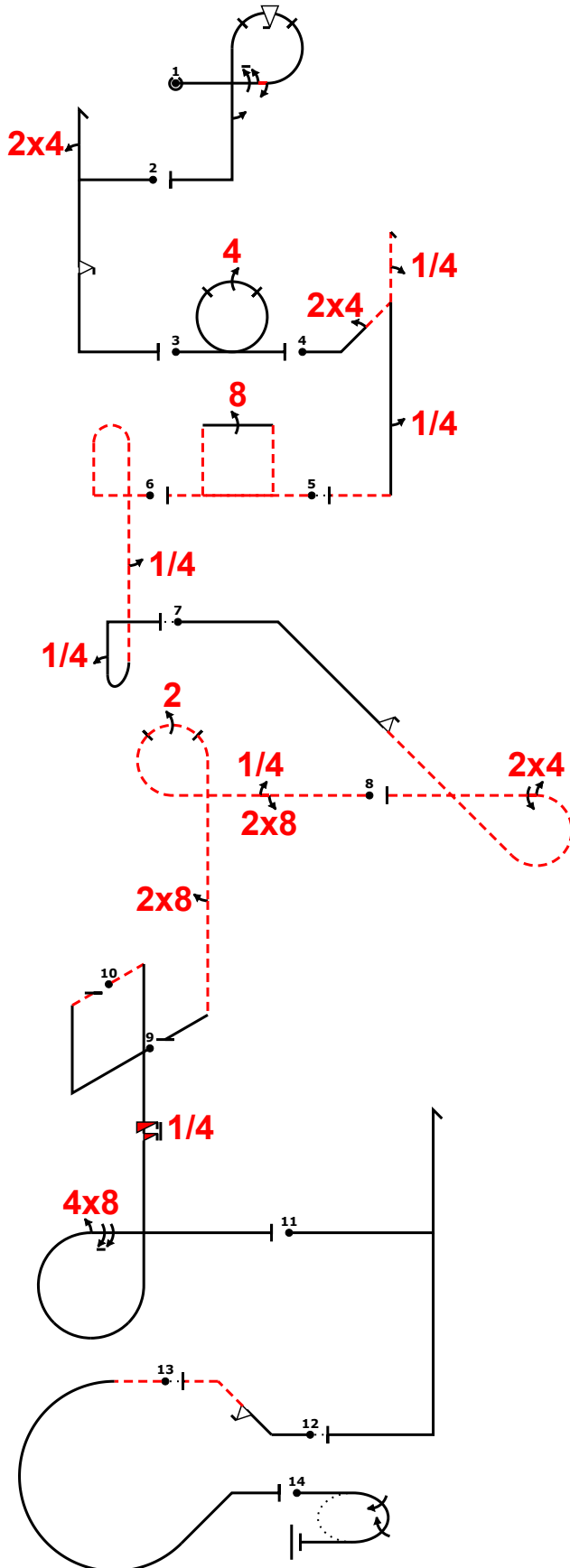

Power		
Fig	Aresti	K
1 D	8.6.5.1	11
	9.1.3.6	10
	9.1.3.2	4
	9.9.3.4	11
	9.1.5.2	4
2 C	5.2.1.1	17
	9.4.1.2	9
	9.9.5.2	11
3 G	7.4.1.1	10
	9.4.3.4	11
4 J	5.3.2.3	25
	9.4.2.2	7
	9.1.1.1	6
5 A	7.4.3.2	19
	9.8.3.4	15
6 Add.	8.8.3.2	23
	9.1.5.1	2
	9.1.1.1	6
7 E	8.5.4.3	14
	9.9.4.2	11
	9.4.3.2	5
	9.1.3.4	8
8 H	8.6.6.2	15
	9.8.3.1	3
	9.1.3.1	2
	9.2.3.4	9
	9.8.5.1	3
9 Add.	1.1.7.1	9
10 I	8.6.2.4	12
	9.12.1.5	6
	9.8.3.2	7
	9.1.3.8	12
11 Add.	5.2.1.1	17
12 B	1.1.3.1	7
	9.9.2.2	13
13 Add.	8.5.5.4	10
14 F	2.2.5.1	22
Total K =		345

A

Pilot
A/C

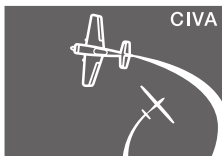

CIVA

FAI

AEROBATICS
COMMISSION

EAAC 2019 1st - 11th Aug

Form B

Pilot ID

CIVA Advanced Unknown3

Flight #

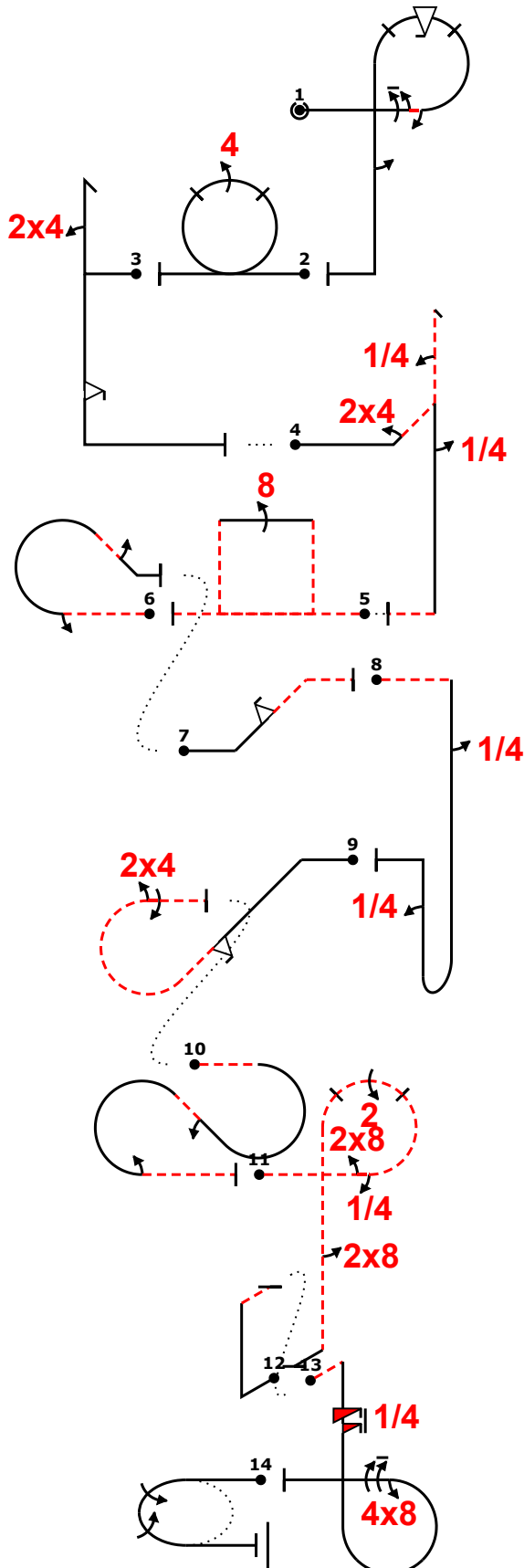
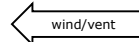

Power			
Fig	Aresti	K	
1 D	8.6.5.1	11	40
	9.1.3.6	10	
	9.1.3.2	4	
	9.9.3.4	11	
	9.1.5.2	4	
2 G	7.4.1.1	10	21
	9.4.3.4	11	
3 C	5.2.1.1	17	37
	9.4.1.2	9	
	9.9.5.2	11	
4 J	5.3.2.3	25	40
	9.4.2.2	7	
	9.1.1.1	6	
	9.1.5.1	2	
5 A	7.4.3.2	19	34
	9.8.3.4	15	
6 Add.	8.5.8.2	11	6
	9.1.3.2	4	
	9.1.4.2	4	
7 B	1.1.3.1	7	20
	9.9.2.2	13	
8 Add.	8.4.2.4	14	6
	9.1.5.1	2	
	9.1.1.1	6	
9 E	8.5.4.3	14	38
	9.9.4.2	11	
	9.4.3.2	5	
	9.1.3.4	8	
10 Add.	7.5.7.4	15	6
	9.1.2.2	6	
	9.1.3.2	4	
11 H	8.6.6.2	15	32
	9.8.3.1	3	
	9.1.3.1	2	
	9.2.3.4	9	
	9.8.5.1	3	
12 Add.	1.1.7.1	9	6
13 I	8.6.2.4	12	37
	9.12.1.5	6	
	9.8.3.2	7	
	9.1.3.8	12	
14 F	2.2.5.1	22	22
Total K = 345			

B

Pilot
A/C

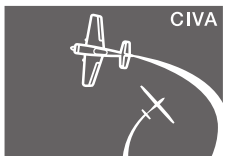

CIVA

FAI

AEROBATICS COMMISSION

EAAC 2019 1st - 11th Aug

Form B

Pilot ID

CIVA Advanced Unknown3

Flight #

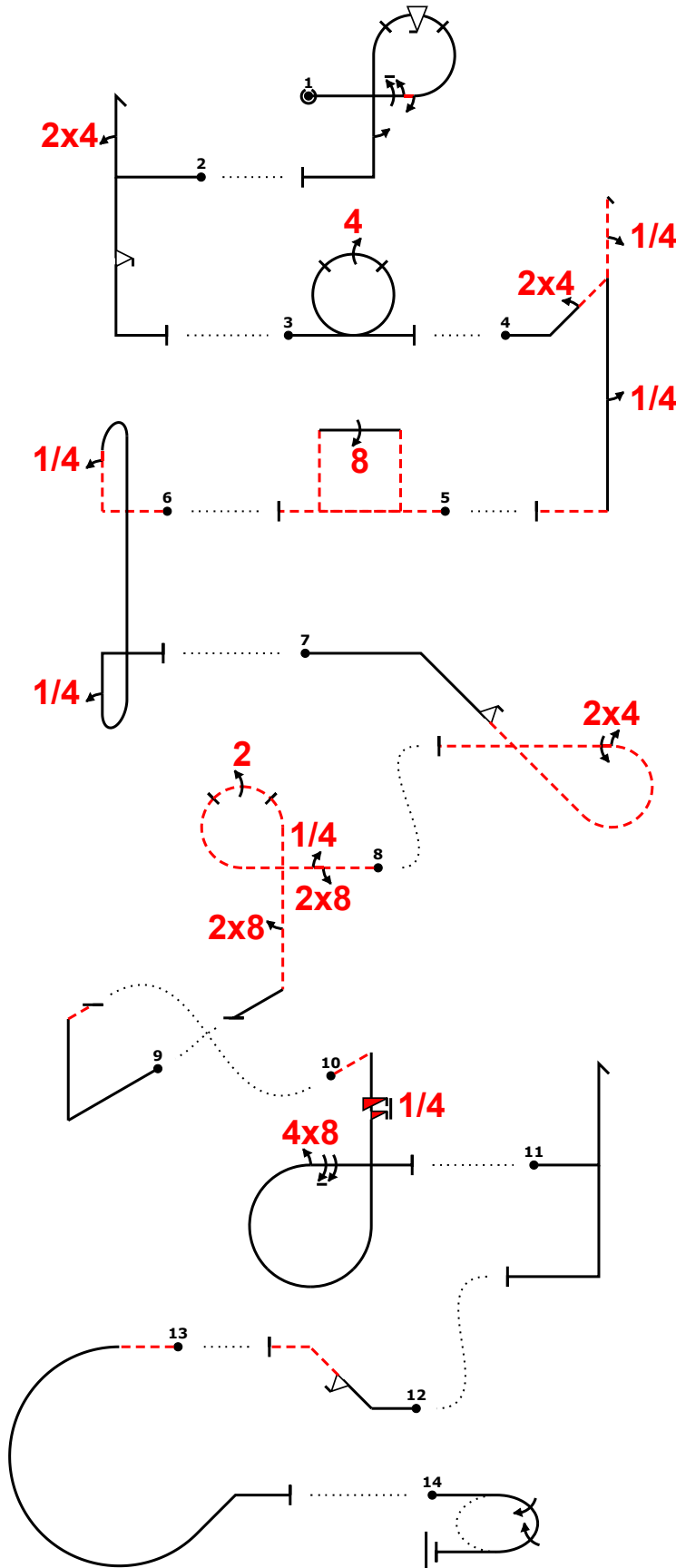
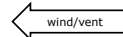

Power		
Fig	Aresti	K
1 D	8.6.5.1	11
	9.1.3.6	10
	9.1.3.2	4
	9.9.3.4	11
	9.1.5.2	4
2 C	5.2.1.1	17
	9.4.1.2	9
	9.9.5.2	11
3 G	7.4.1.1	10
	9.4.3.4	11
4 J	5.3.2.3	25
	9.4.2.2	7
	9.1.1.1	6
	9.1.5.1	2
5 A	7.4.3.2	19
	9.8.3.4	15
6 Add.	8.8.7.2	21
	9.1.1.1	6
	9.1.1.1	6
7 E	8.5.4.3	14
	9.9.4.2	11
	9.4.3.2	5
	9.1.3.4	8
8 H	8.6.6.2	15
	9.8.3.1	3
	9.1.3.1	2
	9.2.3.4	9
9 Add.	9.8.5.1	3
	1.1.7.1	9
	1.1.7.1	9
10 I	8.6.2.4	12
	9.12.1.5	6
	9.8.3.2	7
	9.1.3.8	12
11 Add.	5.2.1.1	17
	5.2.1.1	17
12 B	1.1.3.1	7
	9.9.2.2	13
13 Add.	8.5.5.4	10
	8.5.5.4	10
14 F	2.2.5.1	22
Total K = 345		

Pilot
A/C

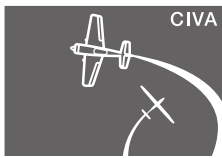

CIVA

FAI

AEROBATICS
COMMISSION

EAAC 2019 1st - 11th Aug

Form B

Pilot ID

CIVA Advanced Unknown3

Flight #

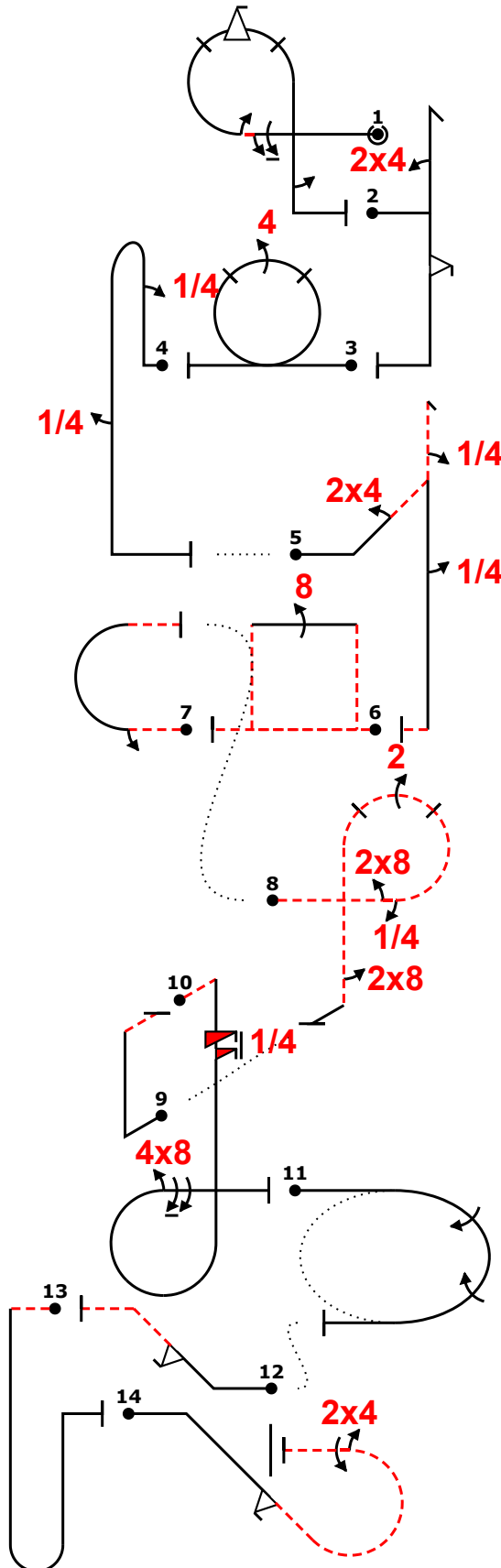
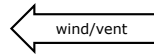

Power			
Fig	Aresti	K	
1 D	8.6.5.1	11	40
	9.1.3.6	10	
	9.1.3.2	4	
	9.9.3.4	11	
	9.1.5.2	4	
2 C	5.2.1.1	17	37
	9.4.1.2	9	
	9.9.5.2	11	
3 G	7.4.1.1	10	21
	9.4.3.4	11	
4 Add.	8.4.1.1	13	6
	9.1.1.1	6	
	9.1.5.1	2	
5 J	5.3.2.3	25	40
	9.4.2.2	7	
	9.1.1.1	6	
	9.1.5.1	2	
6 A	7.4.3.2	19	34
	9.8.3.4	15	
7 Add.	7.2.3.2	7	6
	9.1.3.2	4	
8 H	8.6.6.2	15	32
	9.8.3.1	3	
	9.1.3.1	2	
	9.2.3.4	9	
	9.8.5.1	3	
9 Add.	1.1.7.1	9	6
10 I	8.6.2.4	12	37
	9.12.1.5	6	
	9.8.3.2	7	
	9.1.3.8	12	
11 F	2.2.5.1	22	22
12 B	1.1.3.1	7	20
	9.9.2.2	13	
13 Add.	8.4.2.4	14	6
14 E	8.5.4.3	14	38
	9.9.4.2	11	
	9.4.3.2	5	
	9.1.3.4	8	
Total K = 345			

D

Pilot
A/C

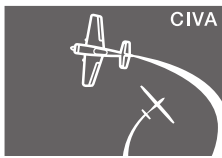

CIVA

FAI

AEROBATICS
COMMISSION

EAAC 2019 1st - 11th Aug

Form B

Pilot ID

CIVA Advanced Unknown3

Flight #

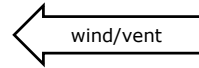

E

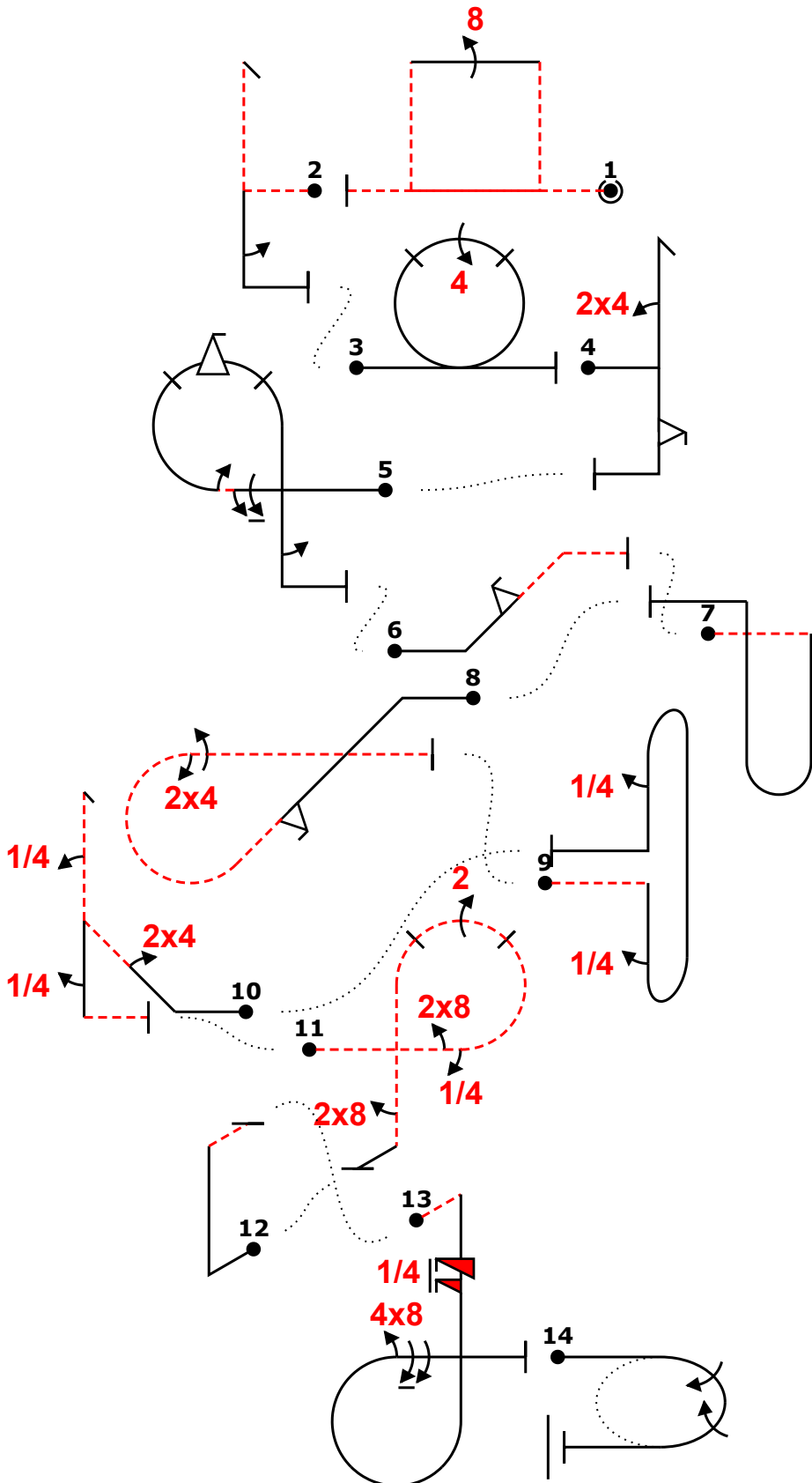

Power			
Fig	Aresti	K	
1	7.4.3.2	19	34
A	9.8.3.4	15	
2	5.2.1.4	22	6
Add.	9.1.5.2	4	
3	7.4.1.1	10	21
G	9.4.3.4	11	
4	5.2.1.1	17	37
C	9.4.1.2	9	
	9.9.5.2	11	
5	8.6.5.1	11	40
D	9.1.3.6	10	
	9.1.3.2	4	
	9.9.3.4	11	
	9.1.5.2	4	
6	1.1.3.1	7	20
B	9.9.2.2	13	
7	8.4.2.4	14	6
Add.			
8	8.5.4.3	14	38
E	9.9.4.2	11	
	9.4.3.2	5	
	9.1.3.4	8	
9	8.8.1.4	18	6
Add.	9.1.5.1	2	
	9.1.5.1	2	
10	5.3.2.3	25	40
J	9.4.2.2	7	
	9.1.1.1	6	
	9.1.5.1	2	
11	8.6.6.2	15	32
H	9.8.3.1	3	
	9.1.3.1	2	
	9.2.3.4	9	
	9.8.5.1	3	
12	1.1.7.1	9	6
Add.			
13	8.6.2.4	12	37
I	9.12.1.5	6	
	9.8.3.2	7	
	9.1.3.8	12	
14	2.2.5.1	22	22
F			
Total K = 345			

Pilot
A/C

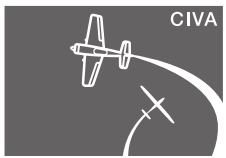

CIVA

FAI

AEROBATICS
COMMISSION

EAAC 2019 1st - 11th Aug

Form B

Pilot ID

CIVA Advanced Unknown3

Flight #

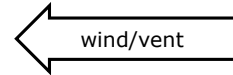

F

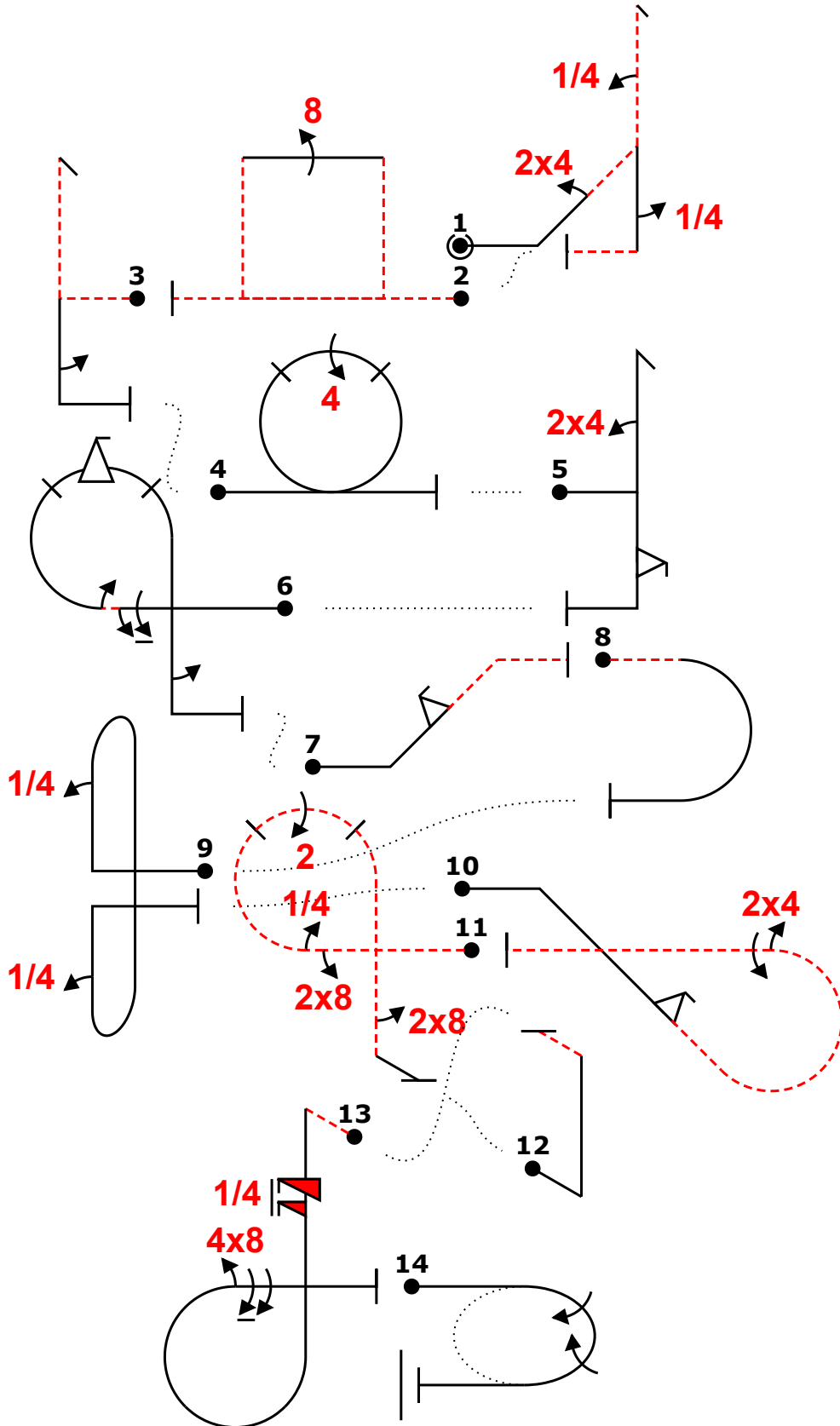

Power			
Fig	Aresti	K	
1 J	5.3.2.3	25	40
	9.4.2.2	7	
	9.1.1.1	6	
	9.1.5.1	2	
2 A	7.4.3.2	19	34
	9.8.3.4	15	
3 Add.	5.2.1.4	22	6
	9.1.5.2	4	
4 G	7.4.1.1	10	21
	9.4.3.4	11	
5 C	5.2.1.1	17	37
	9.4.1.2	9	
	9.9.5.2	11	
6 D	8.6.5.1	11	40
	9.1.3.6	10	
	9.1.3.2	4	
	9.9.3.4	11	
	9.1.5.2	4	
7 B	1.1.3.1	7	20
	9.9.2.2	13	
8 Add.	7.2.1.4	6	6
9 Add.	8.8.2.1	19	6
	9.1.1.1	6	
	9.1.1.1	6	
10 E	8.5.4.3	14	38
	9.9.4.2	11	
	9.4.3.2	5	
	9.1.3.4	8	
11 H	8.6.6.2	15	32
	9.8.3.1	3	
	9.1.3.1	2	
	9.2.3.4	9	
	9.8.5.1	3	
12 Add.	1.1.7.1	9	6
13 I	8.6.2.4	12	37
	9.12.1.5	6	
	9.8.3.2	7	
	9.1.3.8	12	
14 F	2.2.5.1	22	22
Total K = 345			

Pilot
A/C

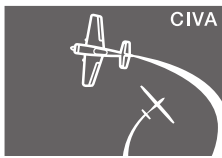

FAI AEROBATICS COMMISSION

EAAC 2019 1st - 11th Aug

Form B

Pilot ID

CIVA Advanced Unknown3

Flight #

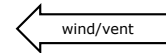

G

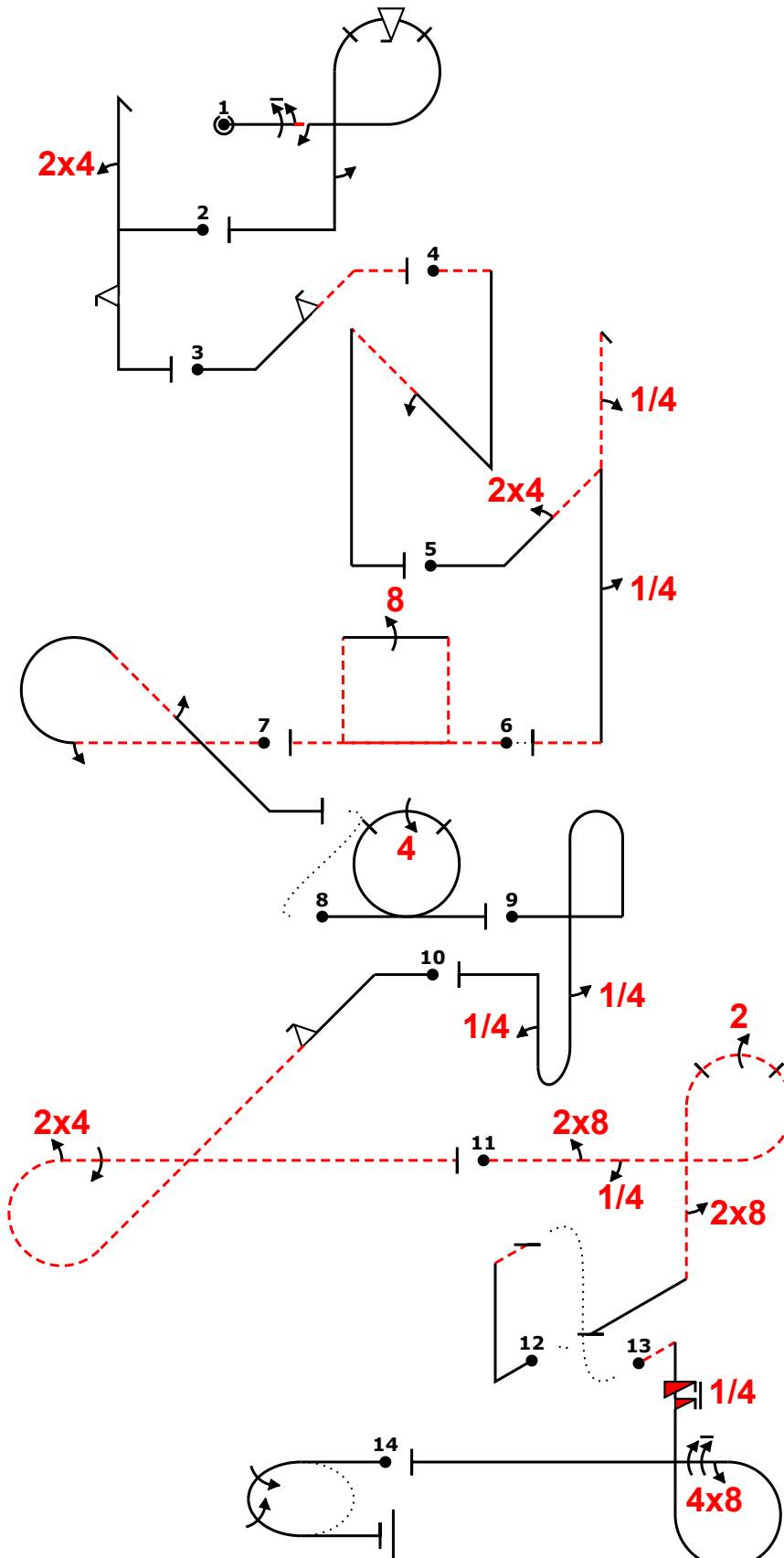

Power			
Fig	Aresti	K	
1 D	8.6.5.1	11	40
	9.1.3.6	10	
	9.1.3.2	4	
	9.9.3.4	11	
	9.1.5.2	4	
2 C	5.2.1.1	17	37
	9.4.1.2	9	
	9.9.5.2	11	
3 B	1.1.3.1	7	20
	9.9.2.2	13	
4 Add.	1.3.11.4	20	6
	9.1.2.2	6	
5 J	5.3.2.3	25	40
	9.4.2.2	7	
	9.1.1.1	6	
	9.1.5.1	2	
6 A	7.4.3.2	19	34
	9.8.3.4	15	
7 Add.	8.5.8.2	11	6
	9.1.3.2	4	
	9.1.4.2	4	
8 G	7.4.1.1	10	21
	9.4.3.4	11	
9 Add.	8.8.2.1	19	6
	9.1.5.1	2	
	9.1.1.1	6	
10 E	8.5.4.3	14	38
	9.9.4.2	11	
	9.4.3.2	5	
	9.1.3.4	8	
11 H	8.6.6.2	15	32
	9.8.3.1	3	
	9.1.3.1	2	
	9.2.3.4	9	
	9.8.5.1	3	
12 Add.	1.1.7.1	9	6
13 I	8.6.2.4	12	37
	9.12.1.5	6	
	9.8.3.2	7	
	9.1.3.8	12	
14 F	2.2.5.1	22	22
Total K = 345			

Pilot
A/C

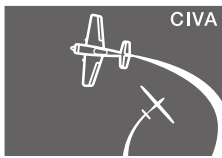

CIVA

FAI

AEROBATICS COMMISSION

EAAC 2019 1st - 11th Aug

Form B

Pilot ID

CIVA Advanced Unknown3

Flight #

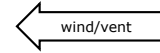

H

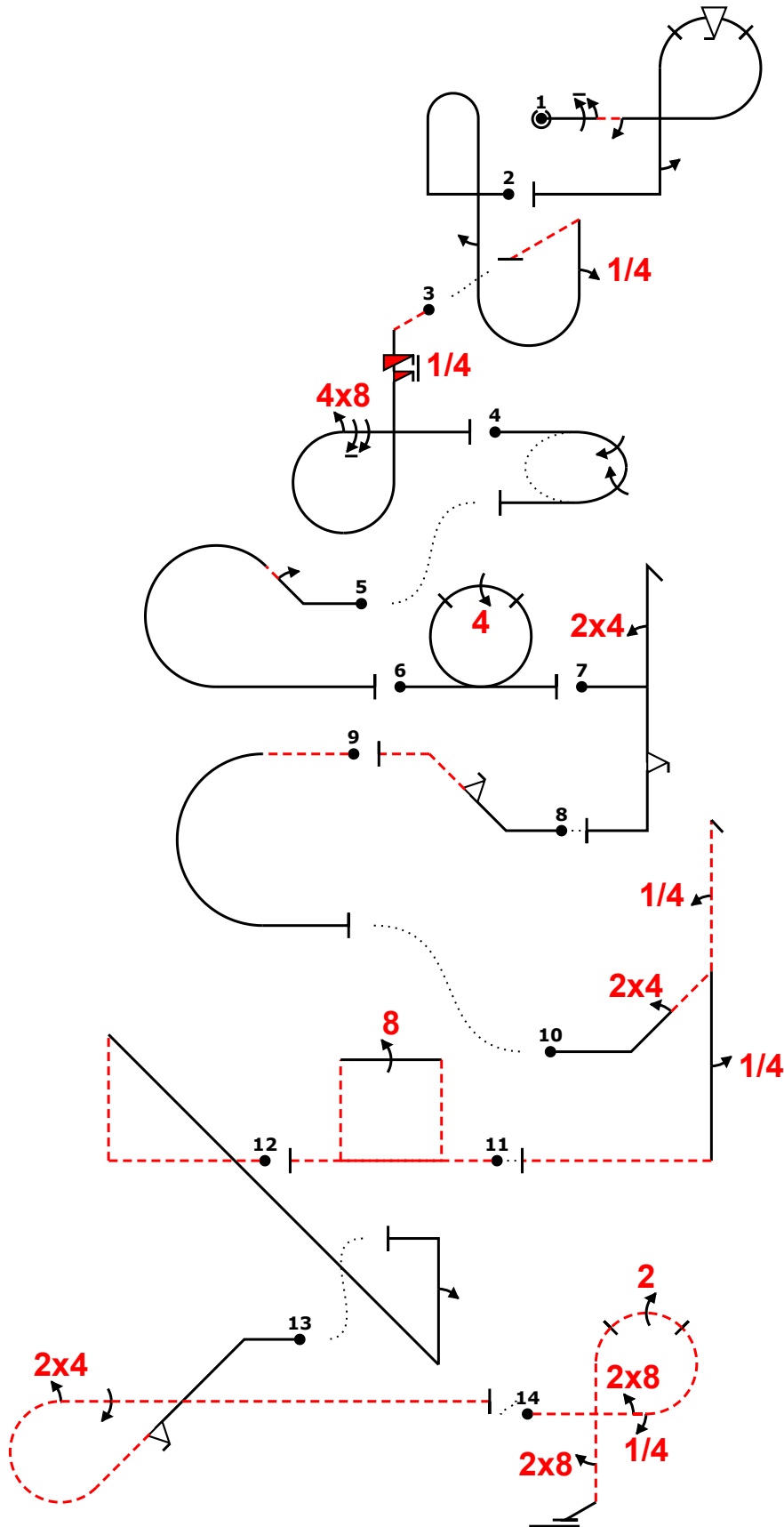

Power			
Fig	Aresti	K	
1 D	8.6.5.1	11	40
	9.1.3.6	10	
	9.1.3.2	4	
	9.9.3.4	11	
	9.1.5.2	4	
2 Add.	8.8.1.1	18	6
	9.1.5.2	4	
	9.1.1.1	6	
3 I	8.6.2.4	12	37
	9.12.1.5	6	
	9.8.3.2	7	
	9.1.3.8	12	
4 F	2.2.5.1	22	22
5 Add.	8.5.2.1	10	6
	9.1.2.2	6	
6 G	7.4.1.1	10	21
	9.4.3.4	11	
7 C	5.2.1.1	17	37
	9.4.1.2	9	
	9.9.5.2	11	
8 B	1.1.3.1	7	20
	9.9.2.2	13	
9 Add.	7.2.1.4	6	6
10 J	5.3.2.3	25	40
	9.4.2.2	7	
	9.1.1.1	6	
	9.1.5.1	2	
11 A	7.4.3.2	19	34
	9.8.3.4	15	
12 Add.	1.3.10.2	24	6
	9.1.1.2	8	
13 E	8.5.4.3	14	38
	9.9.4.2	11	
	9.4.3.2	5	
	9.1.3.4	8	
14 H	8.6.6.2	15	32
	9.8.3.1	3	
	9.1.3.1	2	
	9.2.3.4	9	
	9.8.5.1	3	
Total K = 345			

Pilot
A/C

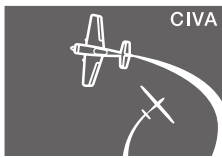

CIVA

FAI

AEROBATICS
COMMISSION

EAAC 2019 1st - 11th Aug

Form B

Pilot ID

CIVA Advanced Unknown3

Flight #

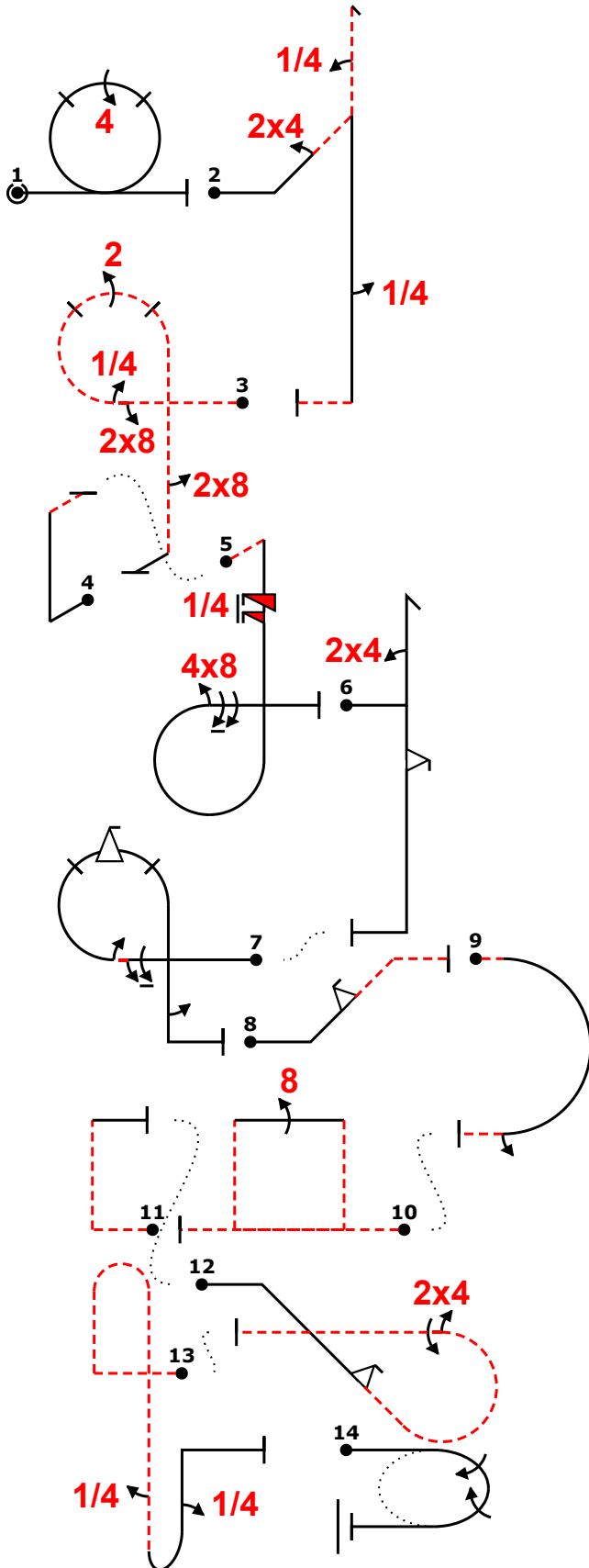
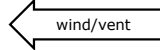

Power			
Fig	Aresti	K	
1 G	7.4.1.1	10	21
	9.4.3.4	11	
2 J	5.3.2.3	25	40
	9.4.2.2	7	
	9.1.1.1	6	
	9.1.5.1	2	
3 H	8.6.6.2	15	32
	9.8.3.1	3	
	9.1.3.1	2	
	9.2.3.4	9	
	9.8.5.1	3	
4 Add.	1.1.7.1	9	6
5 I	8.6.2.4	12	37
	9.12.1.5	6	
	9.8.3.2	7	
	9.1.3.8	12	
6 C	5.2.1.1	17	37
	9.4.1.2	9	
	9.9.5.2	11	
7 D	8.6.5.1	11	40
	9.1.3.6	10	
	9.1.3.2	4	
	9.9.3.4	11	
	9.1.5.2	4	
8 B	1.1.3.1	7	20
	9.9.2.2	13	
9 Add.	7.2.2.4	7	6
	9.1.3.2	4	
10 A	7.4.3.2	19	34
	9.8.3.4	15	
11 Add.	1.1.7.2	12	6
12 E	8.5.4.3	14	38
	9.9.4.2	11	
	9.4.3.2	5	
	9.1.3.4	8	
13 Add.	8.8.3.2	23	6
	9.1.5.1	2	
	9.1.1.1	6	
14 F	2.2.5.1	22	22
Total K = 345			

I

Pilot
A/C



FAI

AEROBATICS COMMISSION

EAAC 2019 1st - 11th Aug

Form B

Pilot ID

CIVA Advanced Unknown3

Flight #

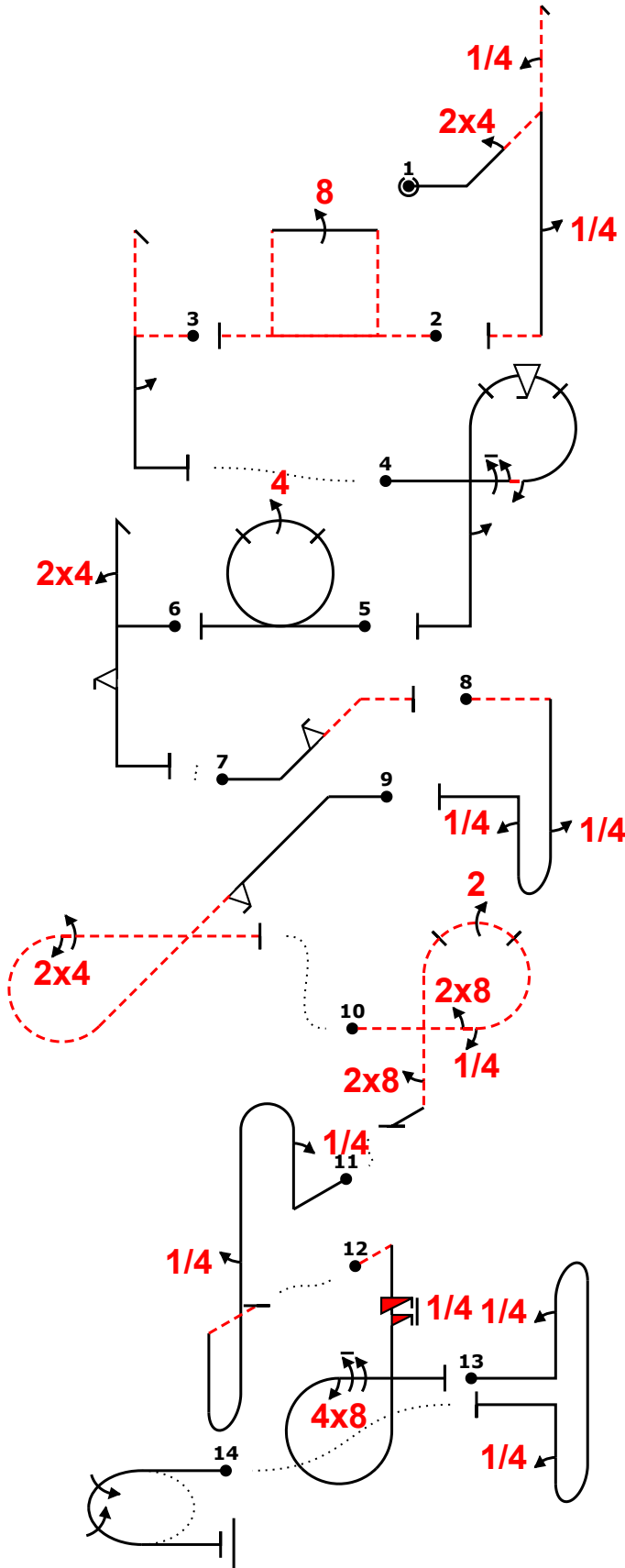
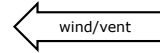

Power			
Fig	Aresti	K	
1	5.3.2.3	25	40
	9.4.2.2	7	
	9.1.1.1	6	
	9.1.5.1	2	
2	7.4.3.2	19	34
	9.8.3.4	15	
3	5.2.1.4	22	6
	9.1.5.2	4	
4	8.6.5.1	11	40
	9.1.3.6	10	
	9.1.3.2	4	
	9.9.3.4	11	
	9.1.5.2	4	
5	7.4.1.1	10	21
	9.4.3.4	11	
6	5.2.1.1	17	37
	9.4.1.2	9	
	9.9.5.2	11	
7	1.1.3.1	7	20
	9.9.2.2	13	
8	8.4.2.4	14	6
	9.1.5.1	2	
	9.1.1.1	6	
9	8.5.4.3	14	38
	9.9.4.2	11	
	9.4.3.2	5	
	9.1.3.4	8	
10	8.6.6.2	15	32
	9.8.3.1	3	
	9.1.3.1	2	
	9.2.3.4	9	
	9.8.5.1	3	
11	8.8.1.1	18	6
	9.1.1.1	6	
	9.1.5.1	2	
12	8.6.2.4	12	37
	9.12.1.5	6	
	9.8.3.2	7	
	9.1.3.8	12	
13	8.8.2.1	19	6
	9.1.1.1	6	
	9.1.1.1	6	
14	2.2.5.1	22	22
Total K = 345			

J

Pilot
A/C



CIVA

FAI

AEROBATICS COMMISSION

EAAC 2019 1st - 11th Aug

Form B

Pilot ID

CIVA Advanced Unknown3

Flight #

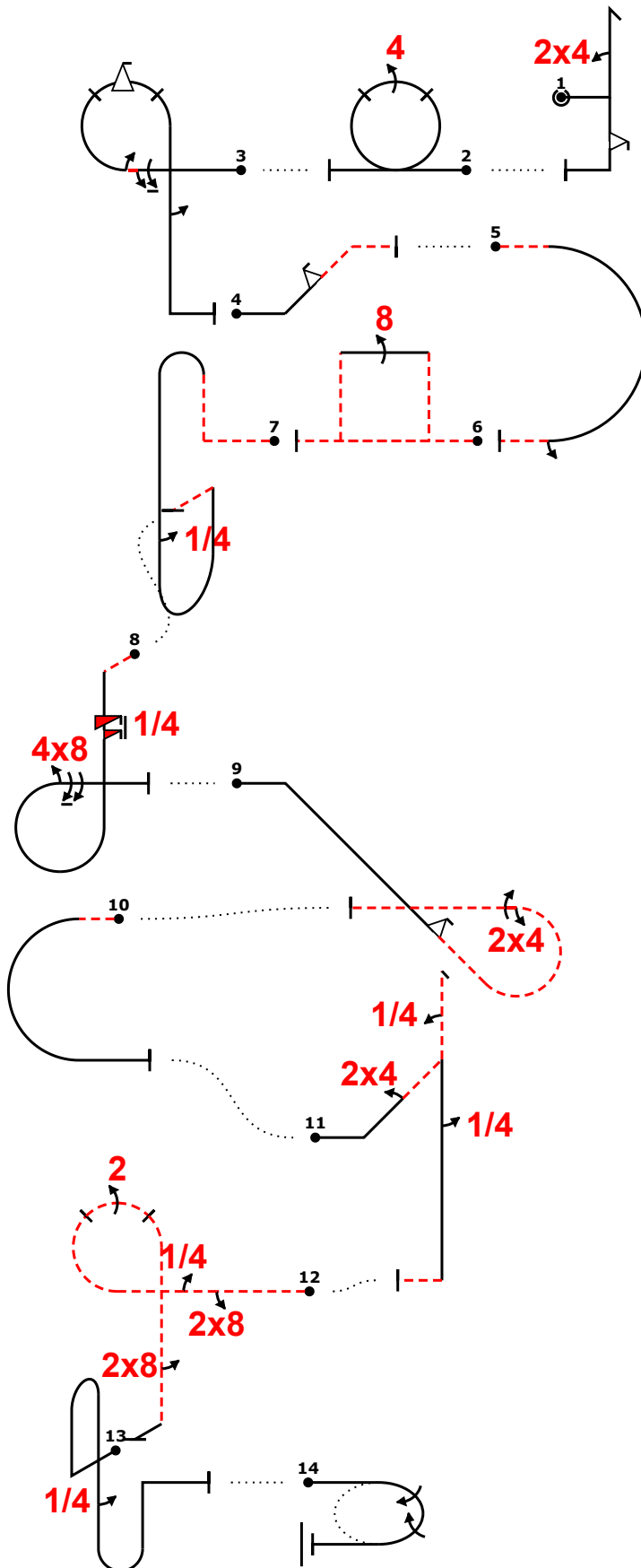

Power		
Fig	Aresti	K
1 C	5.2.1.1	17
	9.4.1.2	9
	9.9.5.2	11
2 G	7.4.1.1	10
	9.4.3.4	11
3 D	8.6.5.1	11
	9.1.3.6	10
	9.1.3.2	4
	9.9.3.4	11
	9.1.5.2	4
4 B	1.1.3.1	7
	9.9.2.2	13
5 Add.	7.2.2.4	7
	9.1.3.2	4
6 A	7.4.3.2	19
	9.8.3.4	15
7 Add.	8.8.8.2	20
	9.1.5.1	2
8 I	8.6.2.4	12
	9.12.1.5	6
	9.8.3.2	7
	9.1.3.8	12
9 E	8.5.4.3	14
	9.9.4.2	11
	9.4.3.2	5
	9.1.3.4	8
10 Add.	7.2.1.4	6
		6
11 J	5.3.2.3	25
	9.4.2.2	7
	9.1.1.1	6
	9.1.5.1	2
12 H	8.6.6.2	15
	9.8.3.1	3
	9.1.3.1	2
	9.2.3.4	9
	9.8.5.1	3
13 Add.	8.8.2.1	19
	9.1.5.1	2
14 F	2.2.5.1	22
Total K = 345		

K

Pilot
A/C